

- Power Requirements** : 110/220V. 60/50Hz. AC (%±10) 24V. DC at standby ~11W. max. ~60W.
- Dimensions** : 450x1000x300 + arm length (470mm)
- Arms** : Ø40mmx2mm 304-Grade (Opt. 316-Grade) Stainless steel (Opt. anodised hard aluminium). Arms can be dismantled or mounted one by one separately.
- Body Features** : 2mm 304-Grade (Opt. 316-Grade) Stainless steel with brushed (Opt. Satin) surface protected against water for outdoors use.
- Indicator Features** : Green Arrow & Red Bar LED
- Operating Temperature, Humidity, IP Rating, MCBF**
 : -20°C to +68°C (Opt. -50°C with heater unit)
 RH 95% non-condensing/IP 54 Outdoor Model (Opt. IP 56)/ 1M Cycles
- Control System** : All inputs are opto-coupler protected. Controlled by dry contact or grounding input. Compatible with all access control systems that provide dry contact or grounding outputs. Optional RS232/RS485/TCP IP control module is available.
- Operation** : Bi-directional passage, manually (Opt. Motorized) operated system.
- Output Data** : The system provides dry contact passage feedback by relays.
- Emergency Mode** : (Standard: Fail Safe); in case of power failure or emergency, the arms free themselves to allow free passage (Opt. Fail Secure).

Flow Rate

: Capacity of Mechanism (Manual System): ~90 passages/minute;
Nominal: ~25 - 46 passage-per-minute (Recommended reference figure)

❖ Explanatory Notes:

- The above given figures are approximate for one person per walkway or lane.
- The system allows the new passage authorisation in less than ~0, 3 seconds. After the passage authorization, the total passage time depends on the pushing and passage speed of the people.
- Utilisation of different access control units can change the flow rate.

Standard Features

: Direction and status indicators on top and sides.

Optional Accessory and Applications:

Remote control units, interface unit for PC, RS485, RS232 and LAN, counter, audio-messaging system, motor driven unit, automatic drop (retractable) arm, alarm sensor, heater positive unit, coin slot/intelligent coin system and coin box, card reader pole, pipe barrier (Separator), floor mounting plate.

**Design and specifications are subject to change without notice.*

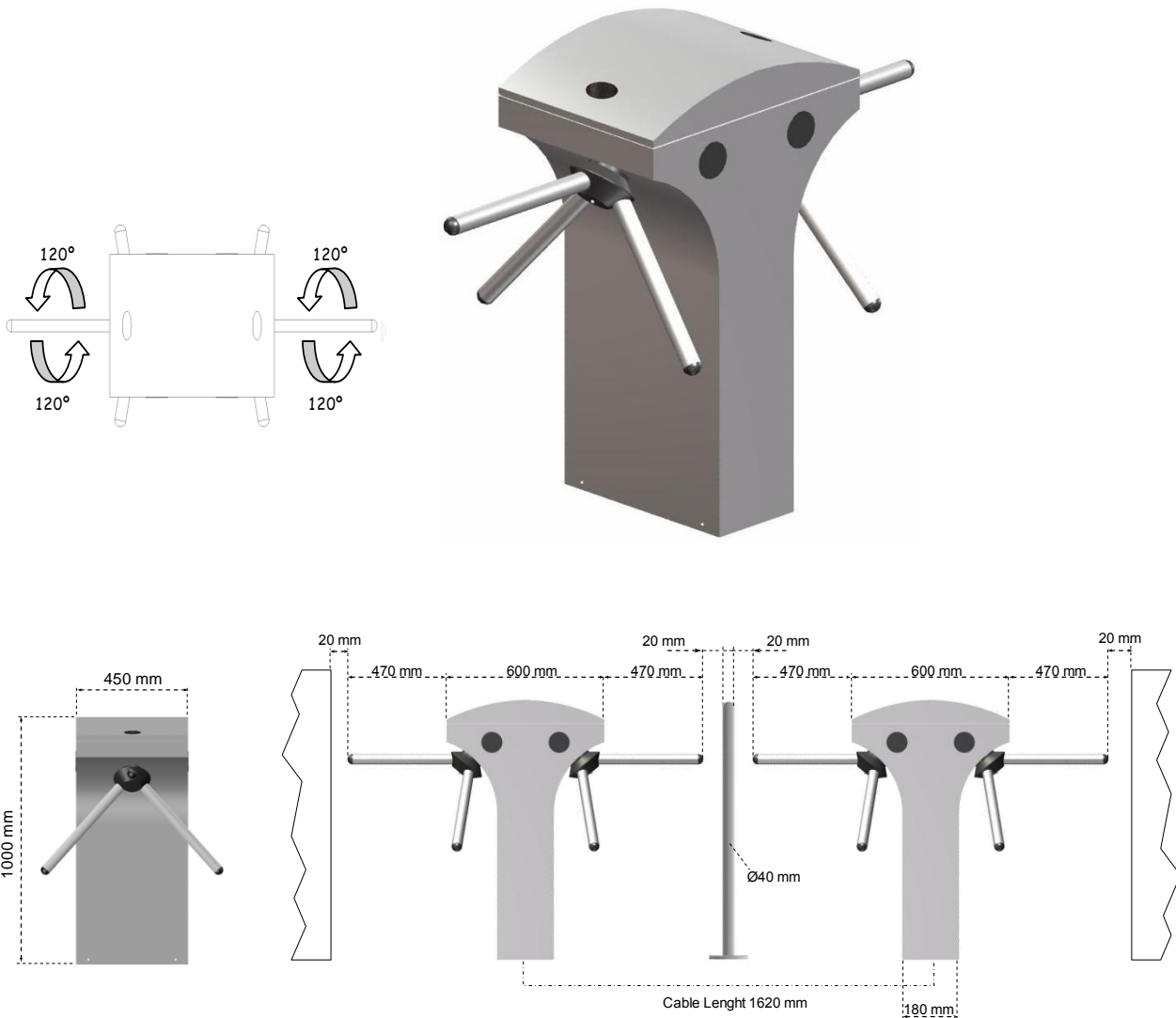

- Power Requirements** : 110/220V. 60/50Hz. AC (%±10) 24V. DC at standby ~22W. max. ~120W.
- Dimensions** : 450x1000x600 + arm length (2x470mm)
- Arms** : Double-sided. Ø40mmx2mm 304-Grade (Opt. 316-Grade) Stainless steel (Opt. anodised hard aluminium). Arms can be dismantled or mounted one by one separately.
- Body Features** : 2mm 304-Grade (Opt. 316-Grade) Stainless steel with brushed (Opt. Satin) surface protected against water for outdoors use.
- Indicator Features** : Green Arrow & Red Bar LED
- Operating Temperature, Humidity, IP Rating, MCBF**
 : -20°C to +68°C (Opt. -50°C with heater unit)
 RH 95% non-condensing / IP 54 Outdoor Model (Opt. IP 56) / 1M Cycles
- Control System** : All inputs are opto-coupler protected. Controlled by dry contact or grounding input. Compatible with all access control systems that provide dry contact or grounding outputs. Optional RS232/RS485/TCP IP control module is available.
- Operation** : Bi-directional passage, manually (Opt. Motorized) operated system.
- Output Data** : The system provides dry contact passage feedback by relays.



602 TECHNICAL SPECIFICATIONS

Emergency Mode : (Standard: Fail Safe); in case of power failure or emergency, the arms rotate freely to allow rapid passage (Opt. Fail Secure).

Flow Rate : Capacity of Mechanism (Manual System) ~90 passages/minute (for double sided 90+90=180)
Nominal~25 - 46 passages-per-minute per side (Recommended reference figure)

❖ **Explanatory Notes:**

- The above given figures are approximate for one person per walkway or lane.
- The system allows the new passage authorisation in less than ~0, 3 seconds. After the passage authorization, the total passage time depends on the pushing and passage speed of the people.
- Utilisation of different access control units can change the flow rate.

Standard Features : Direction and status indicators on top and sides.

Optional Accessory and Applications:

Remote control units, interface unit for PC, RS485, RS232 and LAN, counter, audio-messaging system, motor driven unit, automatic drop (retractable) arm, alarm sensor, heater positive unit, coin slot/intelligent coin system and coin box, card reader pole, pipe barrier (Separator), floor mounting plate.

**Design and specifications are subject to change without notice.*